



# VINYL STAIR COVER - MEDIUM PLANK

Technical data sheet  
English

## General information

Creating an elegant staircase that matches the rest of your interior is straightforward with our Vinyl Stair Covers. You can match them with the design of your floor, and they are scratch and wear resistant, waterproof, easy to clean and easily installed. It's without a doubt the most efficient way to renovate. Stair Covers are available in Medium Planks and Small Planks (not for Alpha Vinyl Tiles).



### Contents

### Composition

### Colour

2 Vinyl stair covers

PVC

Colour-matched

### Order code

### Dimensions

QSVSTRBMP(-)

1474 x 136 x 54 mm

### Applicable for:

- Staircases that have an existing bullnose of maximum 42mm high.
- Staircases that have 90° squared steps.

Available for all decors within following ranges: Alpha Vinyl Medium planks and Alpha Vinyl Small planks.

## Applications

With the Quick-Step Vinyl Stair Covers, you can renovate staircases in the style that you like.

### 1. **Colour-matched staircase**

Finish the riser with an additional cut-to-size floor panel for a full colour-matched staircase.



### 2. **Staircase with painted risers**

Paint the risers with a contrasting colour to accentuate your staircase.



## Features

Thinking of giving your stairs a makeover too? Our Alpha Vinyl is ideal for staircases. With our durable vinyl tread cover, you'll have it done in no time.

✓ **100% colour-match**

Since the Vinyl Stair Covers are made out of the Alpha Vinyl floors, the Stair Covers match your floor perfectly.

✓ **Scratch and wear resistant**

Its ultra-strong core and unique top layer protect against stains, scratches and impact damage.

✓ **Easy to install**

Easily install the Vinyl Stair Covers on your existing staircase with the Quick-Step One4All glue.



## Preparation

Preparation is the key to succes! Follow these steps carefully to guarantee a good installation.

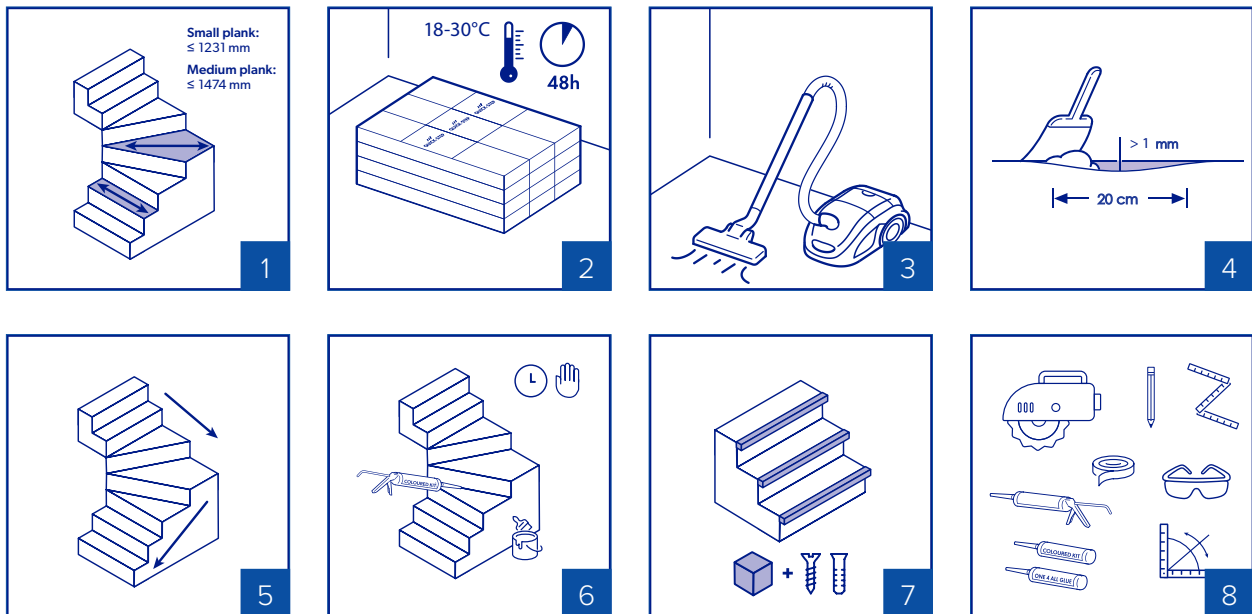

1. The staircovers are designed for closed stairs with risers, with a maximum width of 1474 mm (medium planks) or 1231 mm (small planks) in a standard residential environment. If you have a turn in your stairs, take into account the width of the turned step.
2. The floor and room temperature needs to be maintained prior to, during and for at least 24 hours after the installation is completed. Installation must be performed between 18° - 30°C. Cut out and preserve the label on the box as this information contains the product identity.
3. Remove all dirt, dust and grease from the stair.
4. Any unevenness of more than 1mm (0,04inch) over a length of 20cm (7,87inch) must be levelled out, but we advise leveling out the full stairbase to obtain the best results. Bumps should be removed by sanding or scraping.
5. Start from the top and work your way down when glueing the vinyl stair covers.
6. Painting the sides, risers or seams needs to be done after installing the stair covers.

7. If the stair has no bullnose of its own, create a bullnose yourself.
8. Needed materials:
  - Quick-Step Vinyl Stair Covers and Vinyl planks, see sales organiser for how many planks and stair covers you need for your project
  - Quick-Step One4All glue - 1 cartridge of glue per 2 steps
  - Quick-Step Coloured Kit
  - Caulking gun
  - Tape measure or folding ruler and pencil
  - Tool of your choice to measure angles (eg. Pivot Square)
  - Crosscut and plunge saw, multitool (mind the thickness of the stair cover, be sure to use a compatible plunge saw)
  - Tape
  - If the stair has no existing bullnose, foresee wooden bars, screws and plugs to create a bullnose.

## Installation

### Colour-matched staircase

Below is a list of the installation steps to obtain a correct installation of a fully colour-matched staircase.

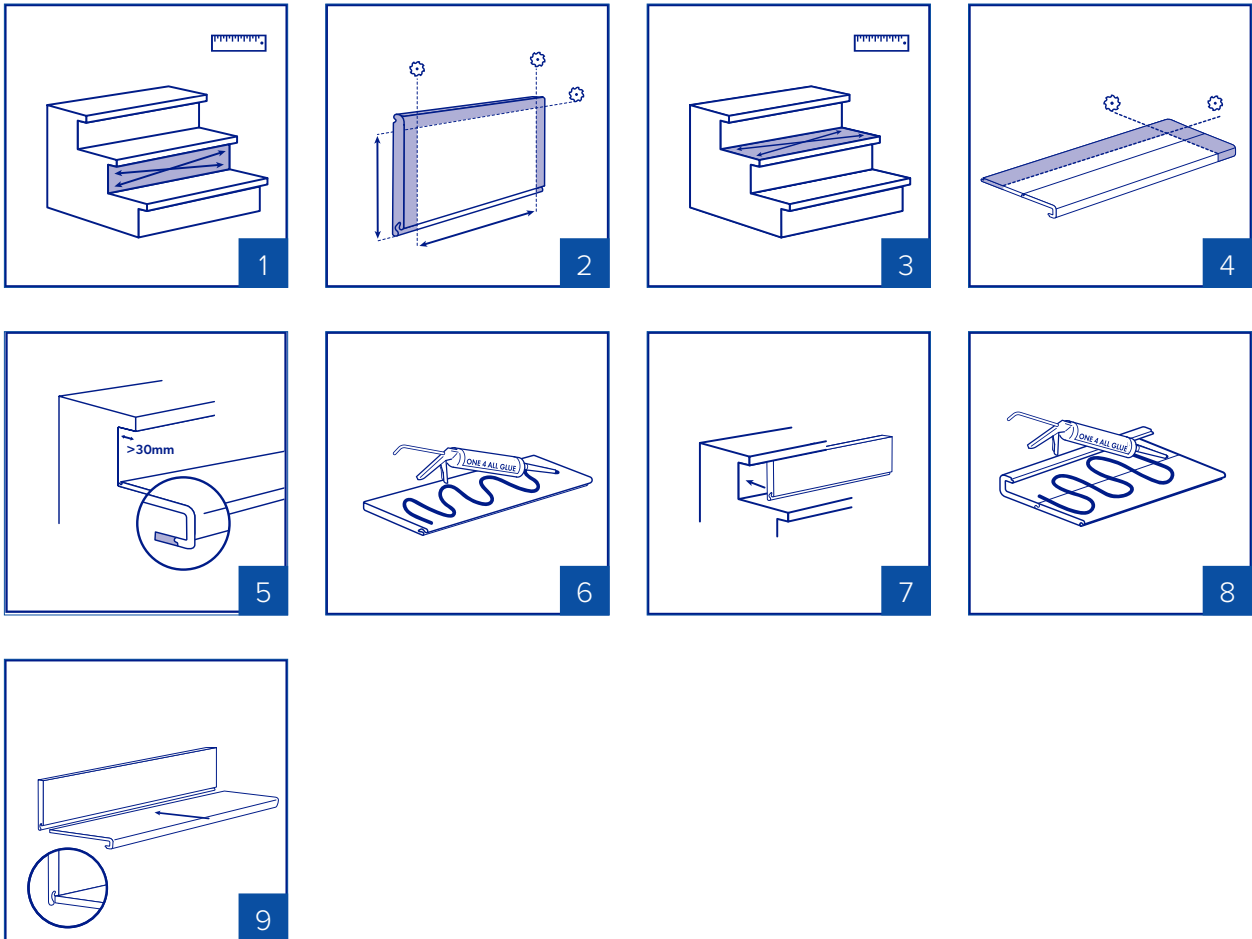

1. Vertical sides: Measure the exact height and width of each riser.
2. To saw a floor plank to size, start measuring from the groove on the long side. Also saw off all other click profiles.

3. Horizontal sides: Measure the exact shape of each step.
4. Click together a stair cover and a vinyl plank. Saw the full vinyl stair cover to size.
5. If the bullnose stands out more than 30 mm from the riser, an additional plank can be clicked in. Tape these two parts together on the backside.
6. Glueing - vertical side: Always perform a dry fit before glueing the stair. Start from the top and glue down the vertical front sides first. Use the recommended glue and glue in a wavy motion so enough glue is applied.
7. Attach each floor panel to the corresponding vertical side of each step, with the groove downwards.
8. Glueing - Horizontal sides: Always perform a dry fit before glueing the stair. First of all, glue down the upper staircover. If the floor on the upper level is installed floating, make sure you use an Incizo between the glued down upper staircover and the floating floor. For each step, click all parts together to cover the tread (the staircover and the piece of floor panel) so that one full staircover is formed. Apply glue on the stairbase in a wavy motion and make sure enough glue is applied.
9. Push each staircover in the groove of the panel that is attached on the riser above. Repeat this for every step.

## Staircase with painted risers

Below is a list of the installation steps to obtain a correct installation of staircase with painted risers.

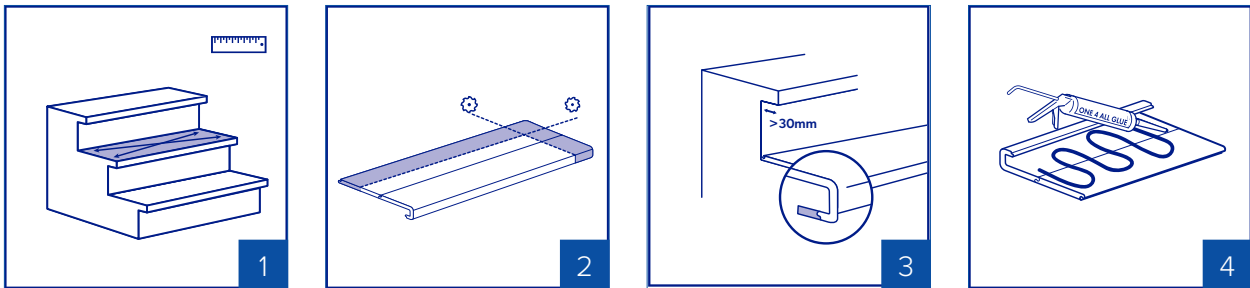

1. Measure the exact shape of each horizontal side of each step.
2. Click together a stair cover and a vinyl plank. Saw the full vinyl stair cover to size.
3. If the bullnose stands out more than 30 mm from the riser, an additional plank can be clicked in. Tape these two parts together on the backside.
4. Glueing: Always perform a dry fit before glueing the stair. First of all, glue down the upper staircover. If the floor on the upper level is installed floating, make sure you use an Incizo between the glued down upper staircover and the floating floor. For each step, click all parts together to cover the tread (the staircover and the piece of floor panel) so that one full staircover is formed. Apply glue on the stairbase in a wavy motion and make sure enough glue is applied.

## Finishing

Below is a list of the finishing steps to obtain the perfect look of your staircase.

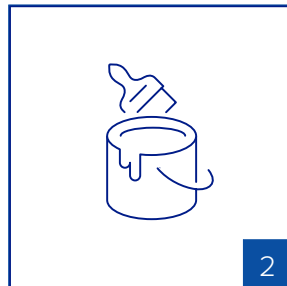
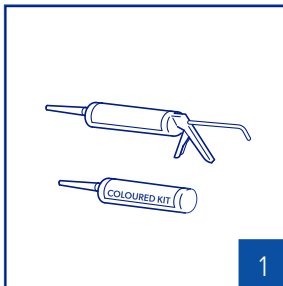

1. Finish seams with Quick-Step Coloured kit (QSKIT(-)) to hide any imperfections. The Coloured kit is available in white and different matching colours to your floor. The coloured kit is also paintable!
2. Finish of your staircase by painting seams, sides or threads as desired.

## Maintenance

Maintenance made easy!

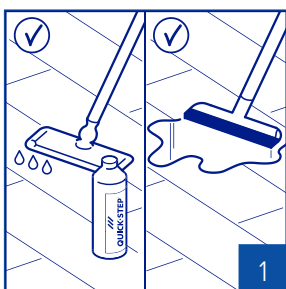

1. Maintain your finished staircase in the same way as your Quick-Step Alpha Vinyl. See [quick-step.com](http://quick-step.com) for Alpha Vinyl maintenance instructions.